

# ATLAS TEX 317

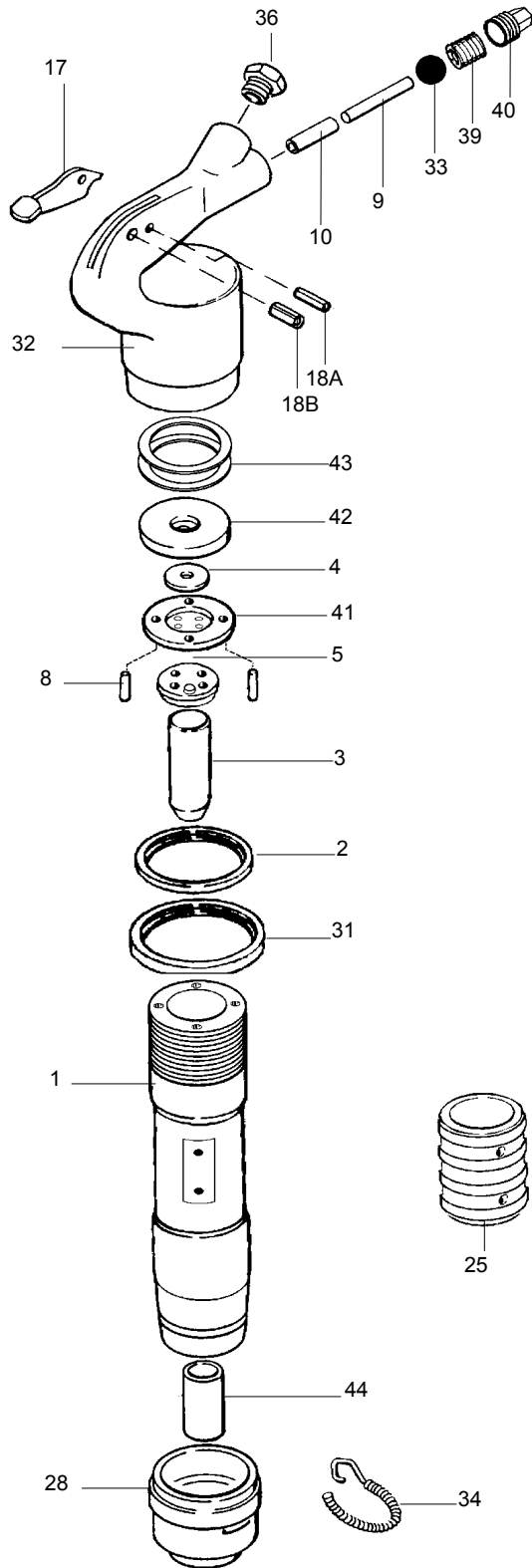

INDEX	PART	DESCRIPTION
1	9245-9962-80	BARREL 2"
	9245-9962-90	BARREL 3"
2	9245-9963-10	LOCK RING BUMPER
3	9245-9963-20	PISTON 2"
	9245-9963-30	PISTON 3"
4	9245-9963-50	PLATE VALVE
5	9245-9963-60	BUMPER VALVE SEAT
8	9245-9963-70	VALVE DOWEL (2)
9	9245-9963-80	PUSH PIN
10	9245-9963-90	PUSH PIN BUSHING
17	9245-9964-00	THROTTLE LEVER
18A	9245-9964-10	LEVER STOP PIN
18B	9245-9964-20	LEVER FULCRUM PIN
25	9245-9964-40	EXHAUST DEFLECTOR (2pc)
28	9245-9853-50	OVAL RETAINER
31	9245-9964-60	HANDLE BARE
32	9245-9964-70	HANDLE COMPLETE
33	9245-9964-80	THROTTLE VALVE BALL
34	9245-9964-90	RETAINER SPRING
35	9245-9965-00	SWIVEL 7/8 x 24"
	9245-9965-10	SWIVEL 3/8 NPT
36	9245-9965-20	HANDLE BUSHING
39	9245-9965-30	THROTTLE VALVE SPRING
40	9245-9965-40	THROTTLE VALVE PLUG
41	9245-9965-50	FRONT VALVE SPACER HOUSING
42	9245-9965-60	UPPER VALVE PLATE
43	9245-9965-70	INTER LOCK RING
44	9245-9965-80	BUSHING FOR .680 ROUND SHANK
	9245-9965-90	BUSHING FOR .580 HEX SHANK

**SERVICE NOTE:** When re-tightening the handle, the **(2) piece inter lock ring 9245-9965-70** must be replaced or the handle will not lock down properly and may vibrate loose during operation. Also apply a small amount of thread locking compound to the barrel threads before the **handle lock ring 9245-9964-50** is tightened in place.

WHEN ORDERING REPLACEMENT PARTS, FURNISH THE MODEL NUMBER(S) AND SERIAL NUMBER (S) OF YOUR TOOLS.

**TEX 317**

**CHIPPING HAMMER**

**17 lb. class**

---

**Specifications –TEX 317**

---

<b>Net Weight</b>	6.4 kg	14 lbs
<b>Length</b>	387 mm	15.25 in
<b>Bore</b>	29 mm	1.125 in
<b>Stroke</b>	102 mm	3 in
<b>Blows per minute</b>	2200	2200
<b>Chuck Sizes</b>	14.8 mm Hex	.580 in Hex 17.5 mm
<b>Rnd</b>	.680 in Rnd	
<b>Air Inlet (NPT)</b>	10 mm	3/8 in



\*estimated

**WHEN  
ORDERING  
TOOLS  
SPECIFY  
CHUCK SIZE**

**WARNING:**

**ALWAYS DISCONNECT THE AIR SUPPLY BEFORE CHANGING CHISELS OR DISMANTLING THE TOOL FOR SERVICE OR REPAIR. FOR MAXIMUM SAFETY WE ADVISE THE INSTALLATION OF A SHUT-OFF VALVE AT THE END OF THE AIR LINE.**