

BACKFILL TAMPER

TEX 640

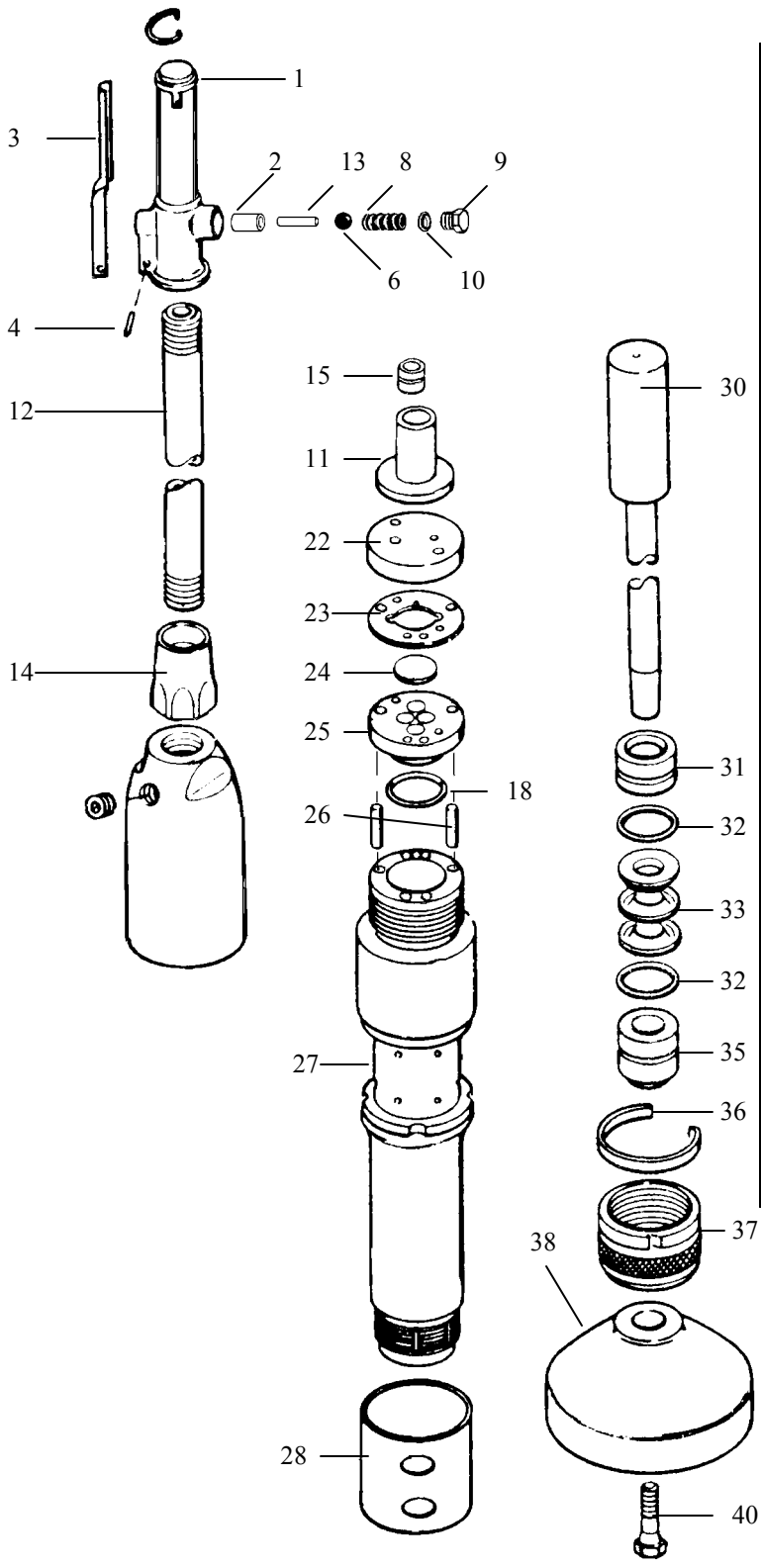

INDEX	PART	DESCRIPTION
NS	9245 9980 10	THROT. BODY COMPLETE
1	9245 9980 15	THROT. BODY BARE
2	9245 9964 85	PUSH PIN BUSHING
3	9245 9980 20	THROTTLE LEVER
4	9245 9964 10	THROTTLE LEVER FULCRUM PIN
5	9245 9980 25	THROTTLE LEVER LOCK CLIP
6	9245 9964 80	THROTTLE BALL
8	9245 9965 30	THROT. BALL SPRING
9	9245 9980 35	THROTTLE VALVE PLUG
10	9245 9980 40	THROTTLE VALVE PLUG O-RING
11	9245 9980 45	OIL RESERVOIR END CAP
12	9245 9980 50	CONNECTING PIPE
13	9245 9963 70	PUSH PIN
14	9245 9980 60	CONNECTING PIPE NUT
15	9245 9980 65	OIL CONTROL BUSHING
16	9245 9980 70	BACKHEAD
NS	9245 9980 75	BACKHEAD ASSY.(ITEM 11,15-17)
17	9245 9980 80	OIL PLUG
18	9245 9980 85	LOWER VALVE BLOCK O-RING
22	9245 9980 90	UPPER VALVE BLOCK
23	9245 9980 95	CENTER PLATE
24	9245 9981 00	VALVE DISK
25	9245 9981 05	LOWER VALVE BLOCK
26	9245 9981 10	VALVE DOWEL PIN (2)
27	9245 9981 15	BARREL
28	9245 9981 20	EXHAUST DEFLECTOR(RUBBER)
30	9245 9981 25	PLUNGER
31	9245 9981 30	UPPER GUIDE BUSHING
32	9245 9981 35	GUIDE BUSHING O-RING (2)
33	9245 9981 40	PLUNGER PACKING SET (3pc set)
35	9245 9981 45	LOWER GUIDE BUSHING
36	9245 9981 50	PACKING NUT LOCK CLIP
37	9245 9981 55	PACKING NUT
38	9245 9981 60	6" MALLEABLE IRON BUTT
NS	9245 9981 65	POLE BUTT
NS	9245 9987 21	3" ALUMINUM BUTT
NS	9245 9990 28	4" ALUMINUM BUTT
40	9245 9981 70	CLAMP SCREW

TEX 640 Tamper 40 lb class



WHEN ORDERING REPLACEMENT PARTS, FURNISH THE MODEL NUMBER(S) AND SERIAL NUMBER(S) OF YOUR TOOLS.

Specifications

Net Weight	17 kg	38.5 lbs
Length	1226 mm	48.25 in
Bore	38 mm	1.5 in
Stroke	140 mm	5.5 in
Blows per minute	1450	1450
Chuck Sizes		804 taper
Air Inlet (NPT)	13 mm	1/2 in
Air Consumption*	1.1 m ³ /m	38.5 cfm

*ESTIMATED

WARNING:

ALWAYS DISCONNECT THE AIR SUPPLY BEFORE CHANGING CHISELS OR DISMANTLING THE TOOL FOR SERVICE OR REPAIR. FOR MAXIMUM SAFETY WE ADVISE THE INSTALLATION OF A SHUT-OFF VALVE AT THE END OF THE AIR LINE.